

32 Channel Digital Input/Output Expansion Board

Introduction

The IO Pi is a 32 channel digital expansion board designed for use on the Raspberry Pi computer platform. The board is based around the MCP23017 16-bit I/O expander from Microchip Technology Inc. A pair of MCP23017 expanders are included on the board allowing you to connect up to 32 digital inputs or outputs to the Raspberry Pi.

The I²C address bits are selectable using the on-board jumpers. The MCP23017 supports up to 8 different I²C addresses so with two MCP23017 devices on each IO Pi you can stack up to 4 IO Pi boards on a single Raspberry Pi giving a maximum of 128 I/O ports.

The IO Pi includes a 5V port that can be isolated from the Raspberry Pi via an isolation jumper so you can use a separate high current power supply to power the IO Pi reducing the load on the Raspberry Pi. Use of an external supply is recommended if you plan on connecting more than one IO Pi to your Raspberry Pi.

For more information on the MCP23017 visit Microchips website at <http://www.microchip.com/wwwproducts/Devices.aspx?dDocName=en023499>

Board Layout

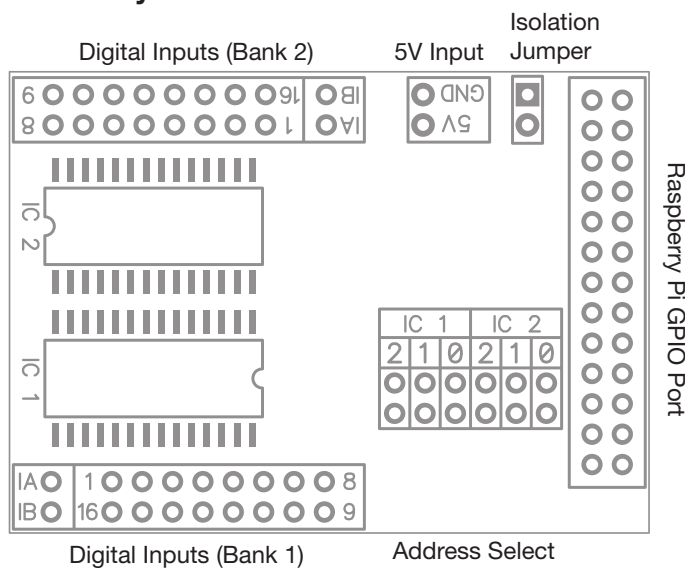

Features

- 32 Digital Inputs/Outputs
- Control via the Raspberry Pi I²C port
- Stack up to 4 IO Pi boards on a single Raspberry Pi
- Jumper selectable I²C addresses
- External 5V Input with isolation jumper
- Based on the MCP23017 from Microchip Technologies Inc
- Configurable interrupt output pins
 - Configurable as active-high, active-low or open-drain
- INTA and INTB can be configured to operate independently or together
- Configurable interrupt source
 - Interrupt-on-change from configured register defaults or pin changes
- Polarity Inversion register to configure the polarity of the input port data

Electrical Characteristics

Vdd (5V input pin when isolation jumper is removed)	4.5V - 5.5V
All digital inputs and outputs	0 - Vdd
Current at I/O Pin (sourced or sunk)	25 mA
Maximum current on a single I/O Bank (1 MCP23017 device)	125 mA

Installation

To install the IO Pi simply press the 26 pin connector down onto the Raspberry Pi GPIO pins with the board sat over the top of the Raspberry Pi as shown in the illustration below.

If you are installing more than one IO Pi on a single Raspberry Pi board then you will need to configure the address select jumpers for each IO Pi as shown on page 2 of this datasheet.

Remove the isolation jumper when connecting an external power supply to the 5V port.

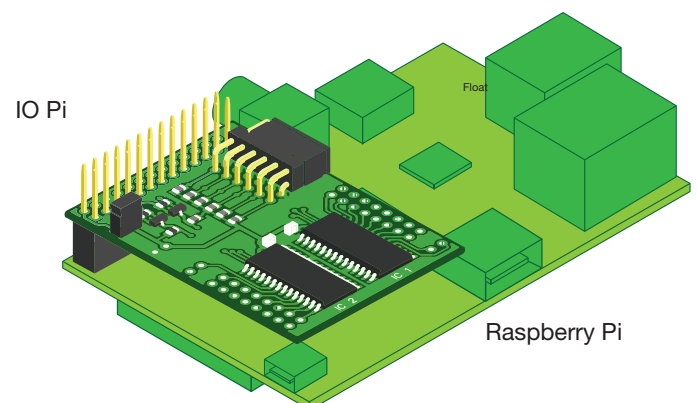

I²C Address Selection

The MCP23017 contains three address select pins which can be tied to Vss, Vdd. This gives 8 possible I²C addresses for each chip. The IO Pi contains two MCP23017 chips so you can stack up to 4 IO Pi boards on a single Raspberry Pi. To simplify address selection on the IO Pi we have included a set of address selection pins which can be configured using the included jumpers. The illustrations below show the four recommended configurations for your IO Pi and the associated I²C addresses.

Note:

Disconnect the IO Pi from the Raspberry Pi before changing the address pins. The address pins are tied to Vdd (high) via a 10K resistor so the jumper is used to tie a pin to ground (low).

Default Configuration (IC1 = 0x20, IC2 = 0x21)

When you purchase the IO Pi the address selection jumpers will be pre-configured to the following addresses.

IC1 Port = I²C Address: 0x20
 IC2 Port = I²C Address: 0x21

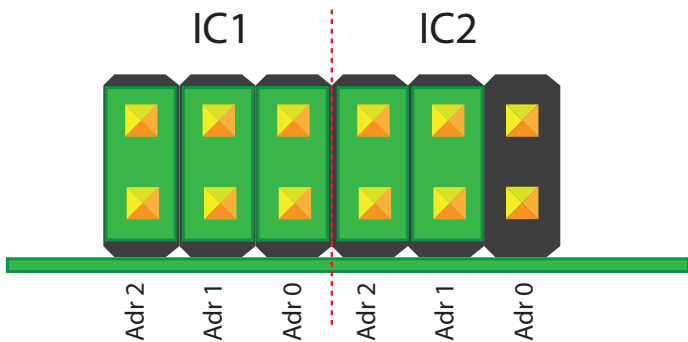

I²C Address Table

Adr 2	Adr 1	Adr 0	I ² C Address
Low	Low	Low	0x20
Low	Low	High	0x21
Low	High	Low	0x22
Low	High	High	0x23
High	Low	Low	0x24
High	Low	High	0x25
High	High	Low	0x26
High	High	High	0x27

Recommended Address Configurations

Configuration 1:

IC1 Port = I²C Address: 0x20
 IC2 Port = I²C Address: 0x21

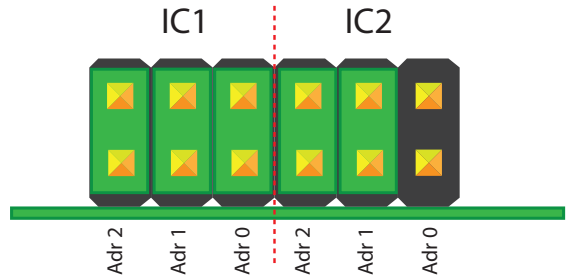

Configuration 2:

IC1 Port = I²C Address: 0x22
 IC2 Port = I²C Address: 0x23

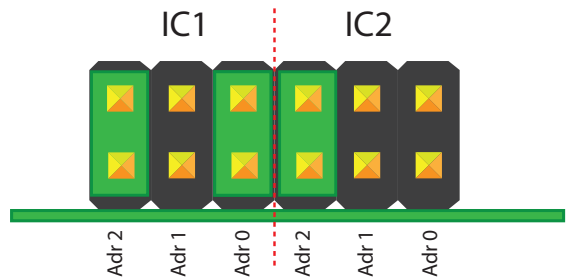

Configuration 3:

IC1 Port = I²C Address: 0x24
 IC2 Port = I²C Address: 0x25

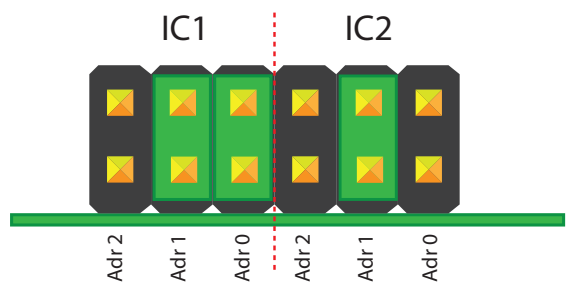

Configuration 4:

IC1 Port = I²C Address: 0x26
 IC2 Port = I²C Address: 0x27

